

概述 Brief introduction



SWL系列蜗轮螺杆升降机是通过蜗轮传动螺杆完成提升、下降、推进、翻转等功能，是一种基础起重部件，已列为JB/T8809-1998标准。广泛地用于机械、冶金、水利、化工、医疗、文化、卫生等各个行业，具有结构紧凑、体积小、重量轻、安装方便、使用灵活、可靠性好、稳定性高、使用寿命长等优点，可以用电动机或其它动力直接带动，也可以手动。本系列蜗轮螺杆升降机可以自锁，承载能力2.5t-120t,最高输入转速1500r/min，最大提升速度2.7m/min，有不同的结构型式和装配方式，工作环境温度在-20-100 C之间，提升高度按用户要求制造。

SWL series worm gear screw jack is a basis jack-up part,accomplish the functions such as lifting,drop,push and inverting through worm gear drives screw.has been in the standard JB/T8809-1998.It is applied to the fields such as machinery,metallurgy,water conservancy,chemical industry,medical treatment,culture and hygienism etc,it has many advantages,such as compact configuration,smallsize,lightweight,convenient installition,flexible operation,high reliability and stability,also has a long service life and more connection form etc,can be driven directly by motor or other power or manual.has self-locking ability,load capacity ranging from 2.5t-120t,input speed up to 1500rpm and lifting speed up to 2.7m/min,ambient temperature:-20-100 C, has different configuration form and assembly type,and the lifting height can highly customized according to user s demand.

型式 Type

2.1 结构型式 Configuration form

- 1型 -蜗轮与螺杆为螺纹联接，螺杆作轴向运动。
- 2型 -蜗轮与螺杆为键联接，螺杆上配螺母，螺杆上的螺母作轴向运动。
- 1 type - worm gear and screw is threaded and coupled and screw does axial motion
- 2 type - worm gear joins screw by key,the screw assembled with nut,and this nut does axial motion.

2.2 装配型式 Assembly type



2.3 螺杆头部型式 Screw head form

1型结构型式螺杆头部分为 I 型（圆柱型）、II 型（法兰型）、III 型（螺纹型）和 IV 型（扁头型）四种型式（见图1）

2型结构型式螺杆头部分为 I 型（圆柱型）和 III 型（螺纹型）两种型式（见图2）。

1 type configuration form,screw head form is: 1 type (cylinder), 2type (flange), 3 type (thread), 4 ytpе(flat head),see chart

2 type configuration form,screw head form is: 1 type (cylinder), 2type (thread),see chart 2.

2.4 传动比 Drive ratio

升降机蜗轮杆传动分为两种传动比，即普通（P）和慢速（M）。

The jack worm gear dear drive ratio divided into two types:normal(P)and slow (M).

2.5 提升承载力 t: Lifting load capacity t

2.5 5 10 15 20 25 35 50 100 120

2.5 5 10 15 20 25 35 50 100 120

2.6 螺杆的防护 Protection of screw

1型升降机螺杆的防护分为：基本型，防旋转型（F）和带防护罩型（Z）；

2型升降机螺杆的防护分为：基本型和带防护罩型（Z）。

protection of 1 type jack screw divided as normal,protective rotation (F) and protective cover attached(Z)

protection of 2 type jack screw divided as normal and protective cover attached (Z).

2.7 标记示例 Mark sample

升降机

SWL2.5 M- 1 A II- 500 FZ



外形及安装尺寸 Outline and installing size

3.1 1型升降机的外形结构尺寸见图1和表1 1 type jack outline size, refer to chart 1 and table 1

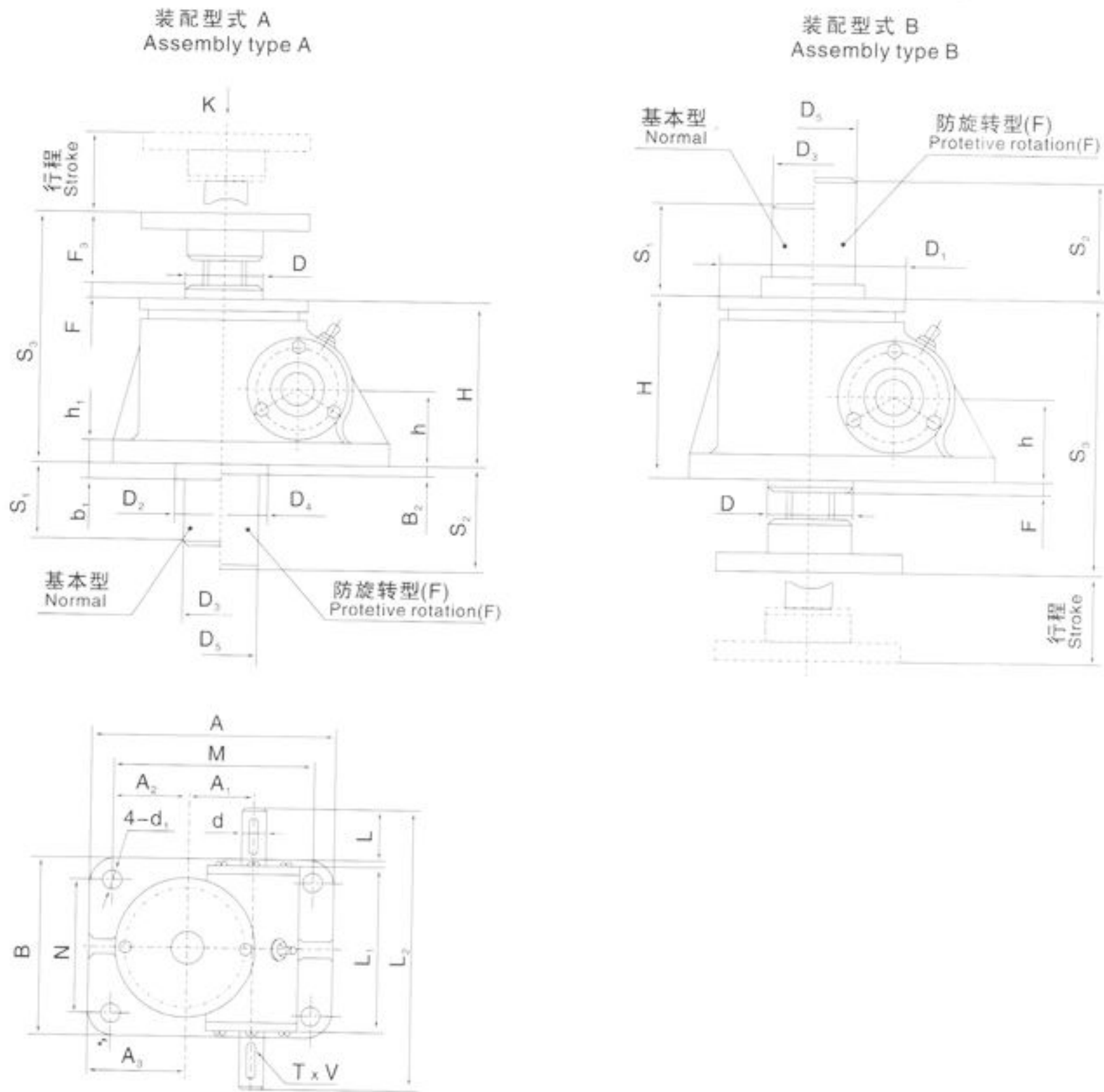

螺杆头部型式 Screw head form



图1 1型结构形式 1 type configuration type

SWL SERIES WORM GEAR SCREW JACK

表1 table1

mm

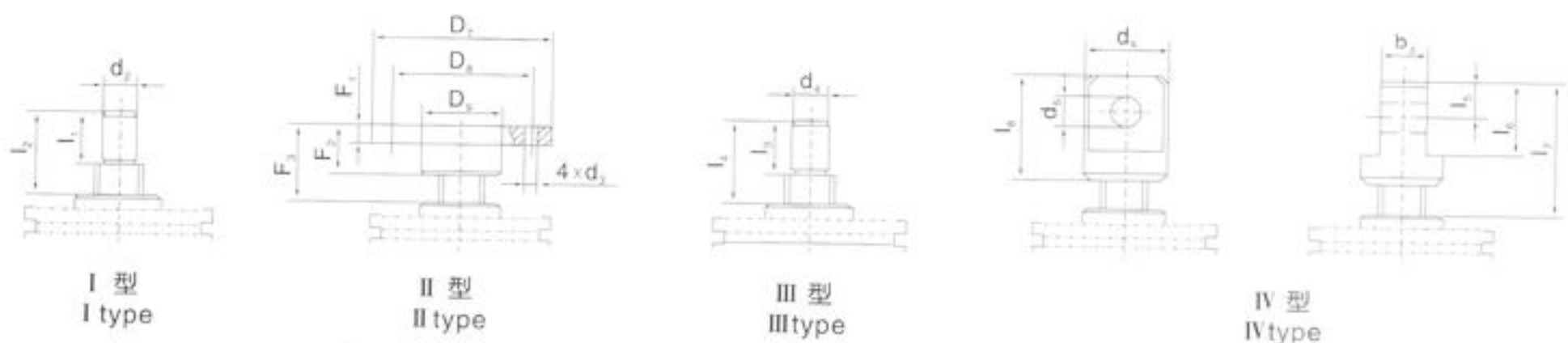
型号 type	SWL2.5	SWL5	SWL10/15	SWL20	SWL25	SWL35	SWL50	SWL100	SWL120		
S ₁	行程+20 stroke+20	行程+20 stroke+20	行程+20 stroke+20	行程+20 stroke+20	行程+20 stroke+20	行程+20 stroke+20	行程+20 stroke+20	行程+20 stroke+20	行程+20 stroke+20		
S ₂	行程+110 stroke+110	行程+110 stroke+110	行程+150 stroke+150	行程+190 stroke+190	行程+205 stroke+205	行程+250 stroke+250	行程+285 stroke+285	行程+350 stroke+350	行程+400 stroke+400		
S ₃	150.5	193	230	262	317	350	416	550	570		
A	165	212	235	295	350	430	475	527.1	526		
B	120	155	200	215	260	280	500	526	622		
M	135	168	190	240	280	360	385	622	412		
N	90	114	155	160	190	210	406	412	508		
H	97	130	150	176	217	240	280	360	360		
h	45	61.5	70	87	102	115	121	155	155		
h ₁	12	14	16	20	25	30	32	38	42		
d(k6)	16	20	25	28	32/34★	38	38	45	48		
d ₁	14	17	21	28	35	35	45	48	48		
GB1096 keyGB1096	5×5×32	6×6×45	8×7×45	8×7×45	10×8×50	10×8×70	10×8×90	14×9×90	14×9×90		
L	32	45	52	52	58	80	100	100	100		
L ₁	110.5	132	172	213.5	221	265	310	380	380		
L ₂	190	228	280	322	355	430	558	610	610		
D	48	65	80	100	130	150	170	240	240		
D ₁	98	122	150	185	205	260	300	420	420		
D ₂	70	90	100	120	150	180	220	310	310		
D ₃	45	60	76	83	114	121	145	180	220		
D ₄	98	110	130	170	200	210	260	370	370		
AMxAM	50×50	60×60	80×80	80×80	120×120	150×150	150×150	200×200	200×200		
A ₁	45	56	67	72	97	120	135	190	190		
A ₂	50	58	63.5	95	95	135	160	166	166		
A ₃	65	80	86	122.5	130	170	205	223	223		
A ₄	-	-	-	-	-	-	-	206	206		
b ₁	20	25	30	35	35	35	45	60	60		
b ₂	12	12	12	15	19	20	25	30	30		
F	8.5	12	6.5	6	8	10	20	36.5	40		
螺杆头部型式 screw head form	I	d ₂ (k6)	20	25	40	50	70	80	95	130	150
		l ₁	30	40	50	58	63	80	90	120	140
		l ₂	45	51	73.5	80	92	100	120	150	170
	II	D ₁	98	122	150	185	205	260	300	370	400
		D ₂	75	85	105	140	155	200	225	280	310
		D ₃	40	50	65	90	100	130	150	200	230
		d ₃	14	17	21	26	27	33	39	48	48
		F ₁	12	18	20	20	25	30	35	75	80
		F ₂	30	40	50	60	63	80	90	120	140
		F ₃	45	51	73.5	80	92	100	120	150	170
	III	d ₄	M22×1.5-6g	M30×2-6g	M42×2-6g	M48×2-6g	M70×3-6g	M80×3-6g	M95×3-6g	M130×4-6g	M150×4-6g
		l ₃	30	39	50	60	63	80	90	120	140
		l ₄	45	51	73.5	80	92	100	120	150	170
		d ₅	50	65	90	110	130	150	180	220	260
	IV	d ₆ (H8)	25	35	50	60	70	80	80	90	95
		b ₃	30	42	60	75	90	105	120	160	180
		l ₅	25	37.5	50	60	70	80	80	90	100
		l ₆	50	75	100	120	140	160	160	180	200
		l ₇	85	117	153.5	175	204	240	270	330	360
		l ₈	70	105	130	150	175	220	240	300	335

★ φ32为SWL25所要求的轴头尺寸, φ34为QWL25所要求的轴头尺寸。

★ φ32 is the shaft head size demanded by SWL25, φ34 is the shaft head size demanded by QWL25.

3.2 2型升降机的外形结构尺寸见图2和表2 2 type jack outline size refer to chart 1 and table 2

装配型式 A
Assembly type A

装配型式 B
Assembly type B

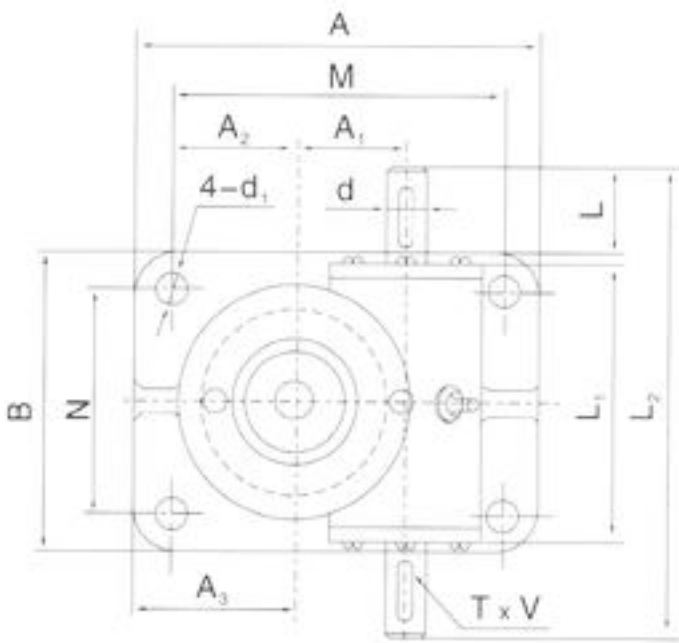
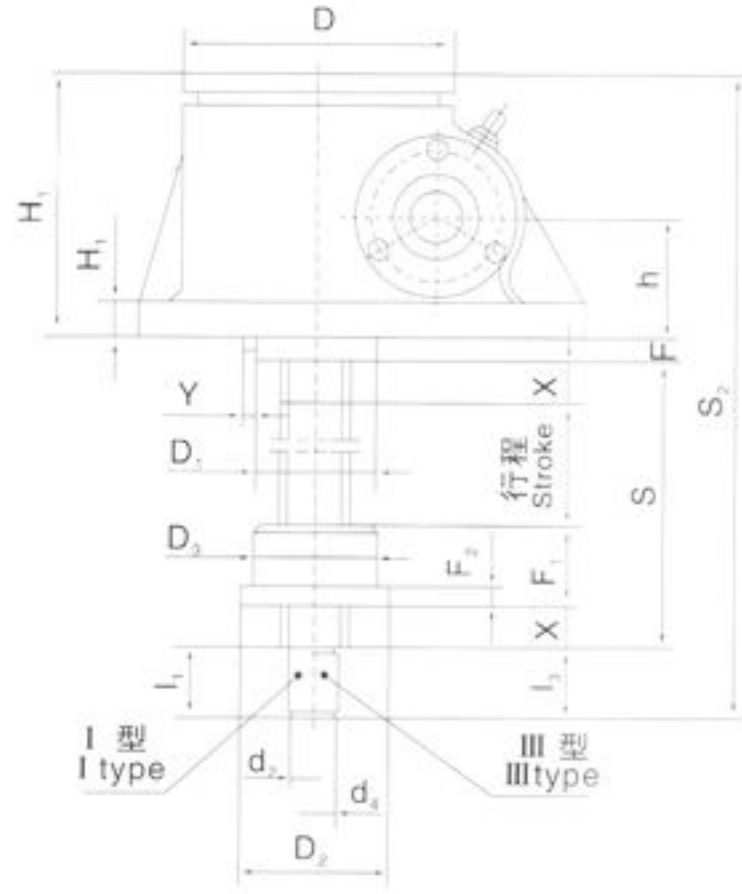
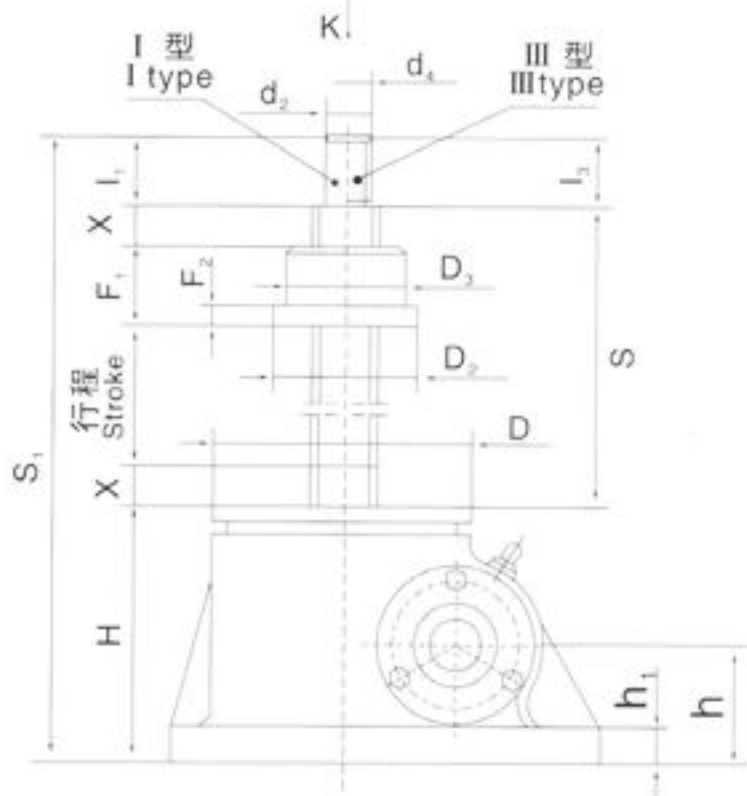

螺杆头部型式
Screw head form



图21 2型结构形式
2 type configuration type

SWL SERIES WORM GEAR SCREW JACK

表2 table2

mm

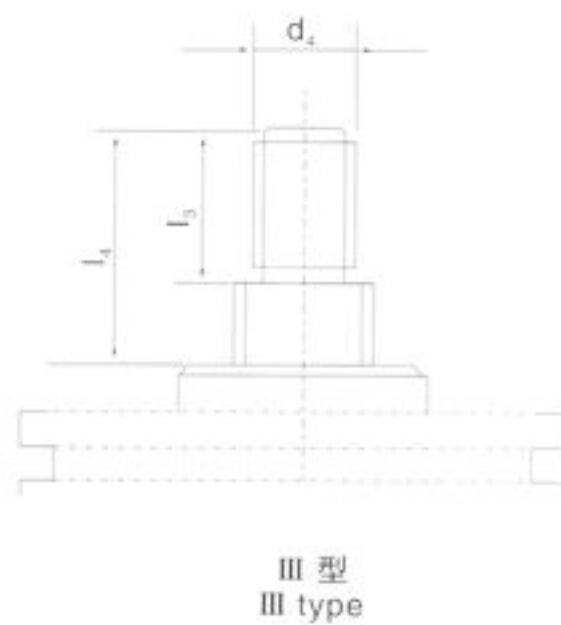
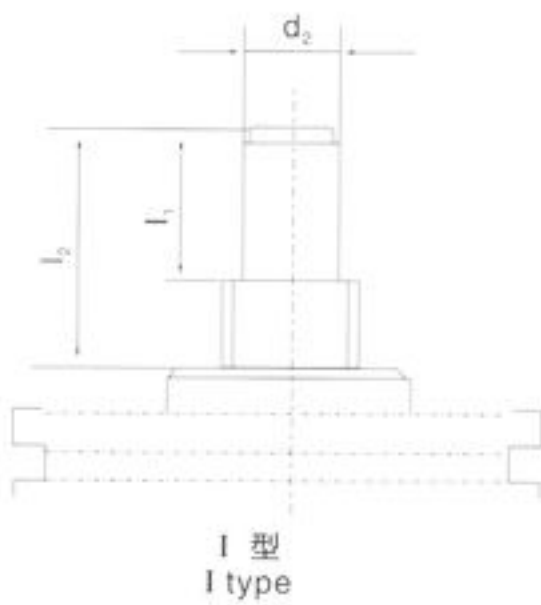
型号 type	SWL2.5	SWL5	SWL10/15	SWL20	SWL25	SWL35	SWL50	SWL100	SWL120		
S	行程+85 stroke+85	行程+100 stroke+100	行程+125 stroke+125	行程+150 stroke+150	行程+170 stroke+170	行程+205 stroke+205	行程+250 stroke+250	行程+320 stroke+320	行程+330 stroke+330		
S ₁	行程+215 stroke+215	行程+270 stroke+270	行程+335 stroke+335	行程+404 stroke+404	行程+476 stroke+476	行程+535 stroke+535	行程+603 stroke+603	行程+815 stroke+815	行程+845 stroke+845		
S ₂	行程+238 stroke+238	行程+300 stroke+300	行程+359 stroke+359	行程+430 stroke+430	行程+519 stroke+519	行程+580 stroke+580	行程+685 stroke+685	行程+880 stroke+880	行程+910 stroke+910		
A	165	212	235	295	350	430	475	526	526		
B	120	155	200	215	260	280	500	622	622		
M	135	168	190	240	280	360	385	412	412		
N	90	114	155	160	190	210	406	508	508		
H	100	131	160	190	226	250	290	375	375		
H ₁	97	131	150	181	211	250	280	360	360		
h	45	61.5	70	87	102	115	121	155	155		
h ₁	12	14	16	20	25	30	32	38	42		
d(k6)	16	20	25	28	34/32★	38	38	45n6	48m6		
d ₁	14	17	21	28	35	35	45	48	48		
键GB1096 keyGB1096	5×5×32	6×6×45	8×7×45	8×7×45	10×8×50	10×8×70	10×8×90	14×9×90	14×9×90		
L	32	45	52	52	56	80	100	100	100		
L ₁	110.5	132	172	213.5	221	265	314	380	380		
L ₂	190	228	280	322	355	430	558	610	610		
D	98	122	150	185	205	260	300	420	420		
D ₁	68	83	110	140	160	180	200	260	260		
A ₁	45	56	67	72	97	120	135	190	190		
A ₂	50	58	63.5	95	95	135	160	166	166		
A ₃	65	80	86	122.5	130	170	205	223	223		
A ₄	-	-	-	-	-	-	-	206	206		
F	26	30	34	39	52	45	65	80	80		
安全裕度X safety tolerance	20	20	25	25	25	30	40	50	50		
Y	3	3	1	3	3	4	5	6	6		
活 动 螺 母 moveable	D ₂	80	87	110	120	155	190	220	300	330	
	D ₃ (h9)	50	70	90	90	130	150	180	240	260	
	F ₁	45	60	75	100	120	145	170	220	270	
	F ₂	15	18	25	30	35	35	50	70	80	
螺 丝 头 部 形 式 screw head form	I	D ₂ (k6)	20	25	40	50	70	80	95	130	150
		L ₁	30	40	50	60	80	80	108	127	130
	III	d _s	M22×1.5-6g	M30×2-6g	M42×2-6g	M48×2-6g	M70×3-6g	M80×3-6g	M95×3-6g	M130×4-6g	M150×4-6g
		l _s	30	39	50	60	63	80	90	120	140

★ φ32为SWL25所要求的轴头尺寸，φ34为QWL25所要求的轴头尺寸。

★ φ32 is the shaft head size demanded by SWL25, φ34 is the shaft head size demanded by QWL25.

性能参数 Performance parameter

4.1 升降机的主要性能参数见表3 parameter of jack, refer to table 3

表3 table 3

型号 type	SWL2.5	SWL5	SWL10/15	SWL20	SWL25	SWL35	SWL50	SWL100	SWL120
最大起升为kN max lifting strength kN	25	50	100/150	200	250	350	500	1000	1200
最大拉力kN max pull foree kN	25	50	99	166	250	350	500	1000	1200
螺杆螺纹尺寸 acrew thread size	Tr30×6	Tr40×7	Tr58×12	Tr65×12	Tr90×16	Tr100×18	Tr120×20	Tr160×23	Tr180×25
蜗轮蜗杆传动比 (p) drive ratio of worm and gear(p)	6:1	6:1	7 $\frac{2}{3}$:1	8:1	10 $\frac{2}{3}$:1	10 $\frac{2}{3}$:1	10 $\frac{2}{3}$:1	12:1	12:1
蜗杆每转行程mm (p) worm stroke per revolurion mm(p)	1.0	1.167	1.565	1.5	1.5	1.69	1.87	1.92	2.083
蜗轮蜗杆转动比 (M) rotational spaad ratio of worm and gear(M)	24:1	24:1	23:1	24:1	32:1	32:1	32:1	36:1	36:1
蜗杆每转行程mm(M) worm stroke per revoiurion mm(M)	0.250	0.292	0.5	0.5	0.5	0.56	0.625	0.638	0.694
蜗杆扭矩N.m worm torqueN.m	见图5-13								
拉力负荷时螺杆 的最大伸长mm max elongation of screw under pull load	1500	2000	2500	3000	3500	4000	5500	6500	7000
侧向力负荷时螺 杆的最大伸长mm max elongation of screw under side force load	见图4-10								
压力负荷时螺 杆的最大伸长mm max elongation of screw under pressure load	见图11-17								
最大许用功率kW max safety power kW	1.45	2.59	3.47	4.02	5.38	13.06	13.9	28.5	62
普通速比 (p) 总效率% general efficiency under normal speed ratio	23	21	23	21	19	18	15	13	12
慢速比 (M) 总效率% general efficiency under slow speed ratio	14	12	15	13	11	11	11	10	8
润滑油量kg lubrioation volume	0.1	0.25	0.5	0.75	1.1	1.9	2.2	2.5	2.5
不加行程的质量kg weight without stroke	7.3	16.2	25	36	70.5	87	420	1010	1350
螺杆每100mm的重量kg screw weight per 100mm	0.45	0.82	1.67	2.15	4.15	5.20	7.45	13.6	17.3

注：1.最大许用功率是在环境温度为20°C,工作持续率为20%h,蜗杆转速为1500r/min的条件下的参数。
2.总效率为油脂润滑条件下的参数。
3.工作环境温度-20°C~+80°C。
4.在静止状态一般可以自锁。

Note:1.the max safety power means this parameter got in this condition;ambient timperature is20°C ,continious running rate is 20%h, worm rotational spaad is 1500r/min
2.general efficiency is a parameter in the grease-lubricated case
3.ambient temperature is -20~+80°C
4.Can be self-locked in stillness state

装配型式与结构型式 Assembly type and configuration form

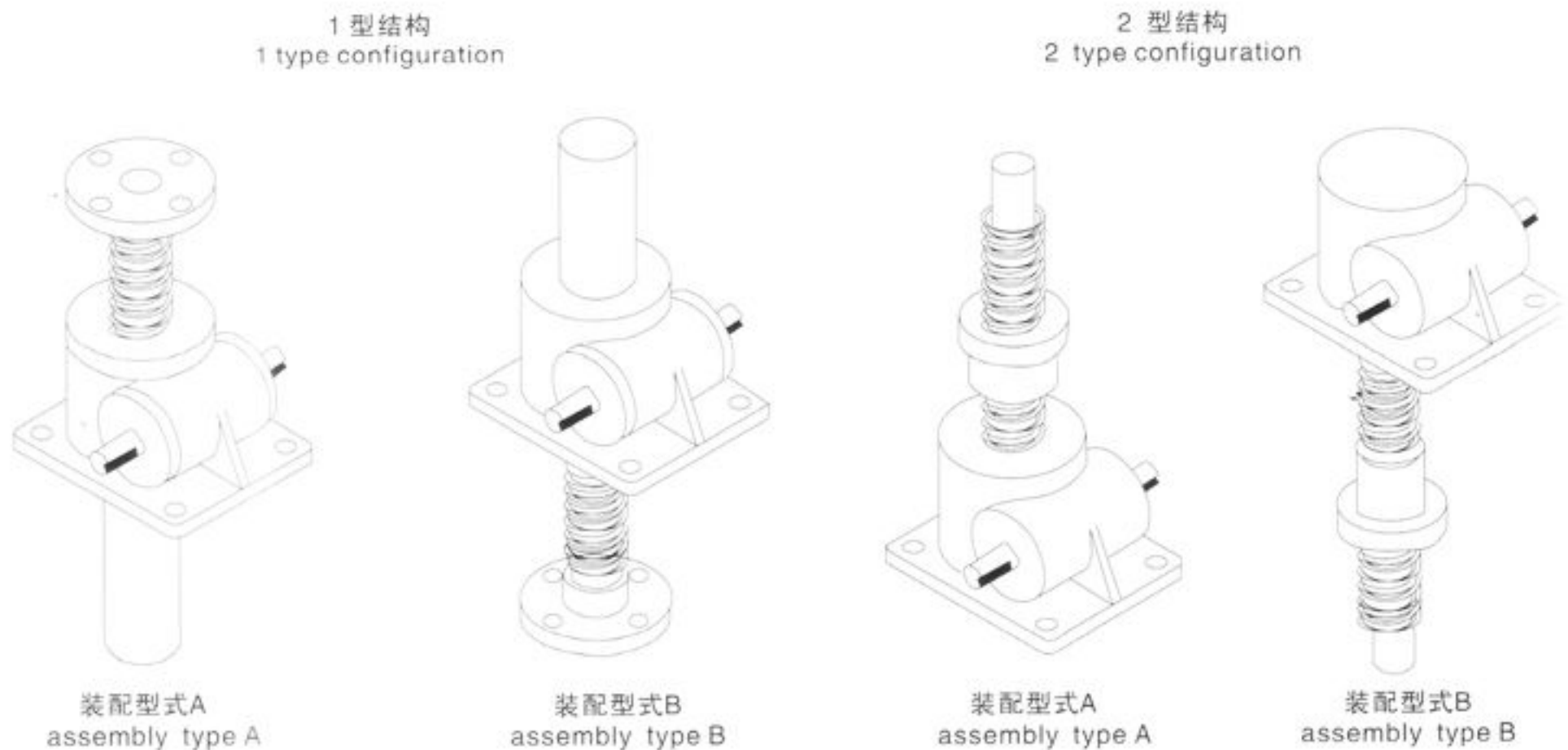

升降机的选择 Jack selection

升降机的主要选择参数为：起升负荷（KN）、螺杆行程（mm）、起升速度（m/min）。

下面给出两种选择方法：

The main parameter to select jacks as so: lifting load(KN), screw stroke(mm), lifting speed (m/min)

Two methods as follows

6.1 选择方法一（仅作选型参考） Method 1 (for refers only)

图11-图17给出了允许弯曲力矩下，。螺杆长度与极限负荷的关系。根据螺杆行程和起升负荷，查图12-图17，查出所需升降机的型号。再根据查出的升降机型号和起升负荷查表4（表4是各种型号在不同的起升负荷下所允许的起升速度），若查出的起升速度满足不了要求，则须选用型号大一规格的升降机，直至满足要求。

Chart 11-chart 17 show the relation between the screw length and limit load under the safety flexural torque, according to screw stroke and lifting load, see chrt 12-chart 17, find out the jack type needed. Then according to the jack type and lifting load table 4 check out if the type meets the need, if the type can, t meet the need, then should select higher grade one, till meets the need. (table 4 shows the safety lifting speed of every type under the different lifting load)

示例 已知：起升负荷为 $F=20\text{KN}$ ，螺杆行程为 200mm ，起升速度 $V=0.45\text{m/min}$ ，试求所需的升降机。

选择升降机：根据 $F=20\text{KN}$ ，行程 200mm ，查图12，选择SWL2.5升降机，查表4起升速度 $V=0.3\text{m/min}$ ，满足不了要求。若选择SWL5升降机，查表4起升速度 $V=0.7\text{m/min}$ ，满足要求，应选择SWL5型升降机。

Example Known conditions: lifting load $F=20\text{KN}$, screw stroke is 200mm , lifting speed $V=0.45\text{m/min}$, selecte the proper jack

Selection process: according to $F=20\text{KN}$, stroke is 200mm , refer to chart 12, select SWL2.5 type, ther refer to table 4, lifting speed $V=0.3\text{m/min}$ which can, t meet the need, so select SWL5 type, refer to table 4 again, the lifting speed $V=0.7\text{m/min}$, meet the need, so should select SWL5 type.

6.2 选择方法二 Method 2

表5-表13是各种型号螺杆传动的许用起升速度、扭距和功率，其参数适用于环境温度为20℃,工作持续率为20%/h或30%/10min的条件下；对粗线范围内的参数，使用时升降机会产生过热，应尽量避免选用，否则必须采取有效措施。根据螺杆起升负荷及起升速度，按照下列公式计算升降机的驱动功率，再查表5-表13，查出所需升降的型号。

Table 5-table 13 is all the sorts of safety lifying speed、torque and power of screw drive,these parameters suitable for this condition; ambient temperature is 20℃,continuous running rate is 20%/h or 30%/10min.those within the thick lines,according to them to select the jack,the jack will overheat,so should avoid selecting speed,calculate the jack s drive power as follow formula,then refer to table 5~table 13,tind out the jack type.

示例 以6.1示例的已知条件进行选择

Example refer to example 6.1

第一步：升降机驱动功率的计算：

First step: calculate drive power

$$\text{驱动功率: } P = \frac{F_a \times v}{60 \eta}$$

$$\text{Drive power: } P = \frac{F_a \times v}{60 \eta}$$

式中：
In formula:

- P——驱动功率，kW
drive power,kW
- F_a——起升力（或拉力），KN
lifting strength
- V——起升速度，m/min
lifting speed,m/min
- η——传递总效率（见表3）
general efficiency of transmission(see table 3)

$$\text{驱动扭矩: } M_t = 9550 \times \frac{P}{n}$$

$$\text{Drive torque: } M_t = 9550 \times \frac{P}{n}$$

式中：
In formula:

- M_t——驱动扭矩，N.m
drive torque
- P——驱动功率，kW
drive power
- n——转速，r/rpm
rotational speed

$$\text{根据公式: 驱动功率 } P = \frac{20 \times 0.45}{60 \times 0.21} = 0.714$$

$$\text{According to the formual: drive power } P = \frac{20 \times 0.45}{60 \times 0.21} = 0.714$$

SWL SERIES WORM GEAR SCREW JACK

第二步：查表5，蜗杆在500r/min，起升速度为0.5m/min，起升负荷为20KN时，许用功率为0.72kW，在粗线范围内，不选用。

Second step: refer to table 5, worm rotational speed is 500r/min, lifting speed is 0.5m/min, lifting load is 20kn, this moment, the safety power is 0.72kw, within thick lines, so can't select it.

第三步：查表6，蜗杆在500r/min，起升速度为0.583m/min，起升负荷为20KN时，许用功率为0.9kW，满足要求，应选择SWL5型升降机。

Third step: refer to table 6, worm rotational speed is 500r/min, lifting speed is 0.5m/min, lifting load is 20kn, this moment, the safety power is 0.9kw, meet the need, so should select SWL type.

表4 table 4

型号 type	起升力F KN lifting strength	普通速比 normal speed ratio		慢速比 slow speed ratio	
		起升速度V m/min lifting speed	蜗杆转速n r/min worm rotational speed	起升速度V _m m/min lifting speed	蜗杆转速n _m r/min worm rotational speed
SWL2.5	25	< 0.05	< 50	< 0.0125	< 50
	20	0.3	300	0.15	600
	15	0.5	500	0.1875	750
	10	0.75	750	0.25	1000
	5	1.5	1500	0.45	1800
	2.5	1.8	1800	0.45	1800
SWL5	50	< 0.0583	< 50	< 0.0146	< 50
	40	0.35	300	0.0175	600
	30	0.35	300	0.219	750
	20	0.7	600	0.292	1000
	10	1.166	1000	0.525	1800
	5	2.1	1800	0.525	1800
SWL10/15	100	0.288	200	0.15	300
	75	0.432	300	0.25	500
	50	0.432	300	0.375	750
	35	0.864	600	0.5	1000
	20	1.44	1000	0.9	1800
	10	2.592	1800	0.9	1800
	5	2.592	1800	0.9	1800
SWL20	200	0.15	100	0.1	200
	160	0.15	100	0.15	200
	120	0.3	200	0.15	300

SWL SERIES WORM GEAR SCREW JACK

续表4 continuous 4

SWL20	100	0.3	200	0.25	500
	75	0.45	300	0.375	750
	50	0.75	500	0.5	1000
	25	1.5	1000	0.9	1800
SWL25	250	0.075	50	0.025	50
	200	0.15	100	0.1	200
	160	0.15	100	0.15	300
	130	0.3	200	0.15	300
	100	0.45	300	0.25	500
	75	0.45	300	0.3	600
	50	0.9	600	0.5	1000
SWL35	350	<0.075	<50	<0.025	<50
	300	0.075	50	0.05	100
	250	0.15	100	0.15	300
	200	0.3	200	0.15	300
	150	0.3	200	0.25	500
	100	0.6	400	0.375	750
	50	1.125	750	0.5	1000
SWL50	500	<0.08	<50	<0.03	<50
	450	0.08	50	0.03	50
	400	0.16	100	0.06	100
	300	0.24	150	0.188	300
	200	0.48	300	0.25	400
	100	0.8	500	0.625	1000
SWL100	1000	<0.08	<50	<0.032	<50
	900	0.08	50	0.032	50
	800	0.159	100	0.064	100
	600	0.238	150	0.096	150
	400	0.317	200	0.192	300
	200	0.635	400	0.639	1000
SWL120	1200	0.104	50	0.035	50
	1000	0.208	100	0.069	100
	900	0.417	200	0.139	200
	800	0.625	300	0.277	400
	600	1.042	500	0.347	500
	400	1.563	750	0.521	750
	200	2.083	1000	0.694	1000

SWL SERIES WORM GEAR SCREW JACK

表5 table5 (SWL2.5)

蜗杆转速 worm rotat- ional speed n r/min	起升力 lifting strength KN																													
	25		20		15		10		5		2.5		1																	
	P	M	P	M	P	M	P	M	P	M	P	M																		
	lifting speed v m/min																													
	P	M	N.m	kW	N.m	kW	N.m	kW	N.m	kW	N.m	kW	N.m	kW	N.m	kW														
1500	1.500	0.375	18	2.7	7.1	1.2	14	2.2	5.7	0.89	11	1.7	4.3	0.67	6.9	1.10	2.9	0.45	3.5	0.54	1.4	0.22	1.7	0.27	0.71	0.11	0.7	0.11	0.28	0.05
1000	1.000	0.250	18	1.8	7.1	0.74	14	1.5	5.7	0.60	11	1.1	4.3	0.45	6.9	0.72	2.9	0.30	3.5	0.36	1.4	0.15	1.7	0.18	0.71	0.07	0.7	0.07	0.28	0.05
750	0.750	0.188	18	1.4	7.1	0.56	14	1.1	5.7	0.45	11	0.82	4.3	0.33	6.9	0.54	2.9	0.22	3.5	0.27	1.4	0.11	1.7	0.14	0.71	0.06	0.7	0.05	0.28	0.05
500	0.500	0.125	18	0.91	7.1	0.37	14	0.72	5.7	0.30	11	0.54	4.3	0.22	6.9	0.36	2.9	0.15	3.5	0.18	1.4	0.07	1.7	0.09	0.71	0.05	0.7	0.05	0.28	0.05
300	0.300	0.075	18	0.54	7.1	0.22	14	0.43	5.7	0.18	11	0.33	4.3	0.13	6.9	0.22	2.9	0.09	3.5	0.11	1.4	0.05	1.7	0.05	0.71	0.05	0.7	0.05	0.28	0.05
200	0.200	0.050	18	0.36	7.1	0.15	14	0.29	5.7	0.12	11	0.22	4.3	0.09	6.9	0.14	2.9	0.06	3.5	0.07	1.4	0.05	1.7	0.05	0.71	0.05	0.7	0.05	0.28	0.05
100	0.100	0.025	18	0.18	7.1	0.07	14	0.14	5.7	0.06	11	0.11	4.3	0.05	6.9	0.07	2.9	0.05	3.5	0.05	1.4	0.05	1.7	0.05	0.71	0.05	0.7	0.05	0.28	0.05
50	0.050	0.013	18	0.09	7.1	0.05	14	0.07	5.7	0.05	11	0.05	4.3	0.05	6.9	0.05	2.9	0.05	3.5	0.05	1.4	0.05	1.7	0.05	0.71	0.05	0.7	0.05	0.28	0.05

表6 table6 (SWL5)

蜗杆转速 worm rotat- ional speed n r/min	起升力 lifting strength KN																													
	25		20		15		10		5		2.5		1																	
	P	M	P	M	P	M	P	M	P	M	P	M																		
	lifting speed v m/min																													
	P	M	N.m	kW	N.m	kW	N.m	kW	N.m	kW	N.m	kW	N.m	kW	N.m	kW														
1500	1.750	0.438	44.2	6.9	19.3	3.0	35.4	5.6	15.5	2.4	26.5	4.2	11.6	1.8	17.7	2.8	7.7	1.2	8.8	1.4	3.9	0.6	4.4	0.7	1.9	0.3	2.2	0.3	1.0	0.2
1000	1.167	0.292	44.2	4.6	19.3	2.0	35.4	3.7	15.5	1.6	26.5	2.8	11.6	1.2	17.7	1.9	7.7	0.8	8.8	0.9	3.9	0.4	4.4	0.5	1.9	0.2	2.2	0.2	1.0	0.1
750	0.875	0.219	44.2	3.5	19.3	1.5	35.4	2.8	15.5	1.2	26.5	2.1	11.6	0.9	17.7	1.4	7.7	0.6	8.8	0.7	3.9	0.3	4.4	0.3	1.9	0.2	2.2	0.2	1.0	0.1
500	0.583	0.146	44.2	2.3	19.3	1.0	35.4	1.9	15.5	0.8	26.5	1.4	11.6	0.6	17.7	0.9	7.7	0.4	8.8	0.5	3.9	0.2	4.4	0.2	1.9	0.1	2.2	0.1	1.0	0.1
300	0.350	0.088	44.2	1.4	19.3	0.6	35.4	1.1	15.5	0.5	26.5	0.8	11.6	0.4	17.7	0.6	7.7	0.2	8.8	0.3	3.9	0.1	4.4	0.1	1.9	0.1	2.2	0.1	1.0	0.1
200	0.233	0.058	44.2	0.9	19.3	0.4	35.4	0.7	15.5	0.3	26.5	0.6	11.6	0.2	17.7	0.4	7.7	0.2	8.8	0.2	3.9	0.1	4.4	0.1	1.9	0.1	2.2	0.1	1.0	0.1
100	0.117	0.029	44.2	0.5	19.3	0.2	35.4	0.4	15.5	0.2	26.5	0.3	11.6	0.1	17.7	0.2	7.7	0.1	8.8	0.1	3.9	0.1	4.4	0.1	1.9	0.1	2.2	0.1	1.0	0.1
50	0.058	0.015	44.2	0.2	19.3	0.1	35.4	0.2	15.5	0.1	26.5	0.1	11.6	0.1	17.7	0.1	7.7	0.1	8.8	0.1	3.9	0.1	4.4	0.1	1.9	0.1	2.2	0.1	1.0	0.1

表7 table7 (SWL10/15)

SWL SERIES WORM GEAR SCREW JACK

表9 table9 (SWL25)

蜗杆转速 worm rotat- ional speed n r/min	起升力 lifting strength KN																											
	起升速度 lifting speed v m/min		250		200		160		120		100		75		50													
	P	M	N.m	kW	N.m	kW	N.m	kW	N.m	kW	N.m	kW	N.m	kW	N.m	kW												
1500	1.500	0.500	314	33	181	19	252	27	145	16	22	116	13	151	16	87	9.1	126	14	73	7.6	95	55	5.7	63	6.6	37	3.8
1000	1.125	0.375	314	25	181	15	252	20	145	12	16	116	9.1	151	12	87	6.8	126	9.9	73	5.7	95	55	4.3	63	4.9	37	2.8
750	0.750	0.250	314	17	181	9.5	252	14	145	7.6	11	116	6.1	151	7.9	87	4.5	126	6.6	73	3.8	95	55	2.8	63	3.3	37	1.9
500	0.600	0.200	314	14	181	7.6	252	11	145	6.1	8.4	116	4.8	151	6.3	87	3.6	126	5.3	73	3.0	95	55	2.3	63	2.6	37	1.5
300	0.450	0.150	314	9.9	181	5.7	252	7.9	145	4.5	6.3	116	3.6	151	4.7	87	2.7	126	3.9	73	2.3	95	55	1.8	63	2.0	37	1.1
200	0.300	0.100	314	6.6	181	3.8	252	5.3	145	3.0	4.2	116	2.4	151	3.2	87	1.7	126	2.6	73	1.5	95	55	1.1	63	1.3	37	0.8
100	0.150	0.050	314	3.3	181	1.9	252	2.6	145	1.5	2.1	116	1.2	151	1.6	87	0.9	126	1.3	73	0.8	95	55	0.6	63	0.7	37	0.4
50	0.075	0.025	314	1.6	181	0.9	252	1.3	145	0.8	1.1	116	0.6	151	0.8	87	0.5	126	0.7	73	0.4	95	55	0.3	63	0.3	37	0.2

表10 table10 (SWL35)

蜗杆转速 worm rotat- ional speed n r/min	起升力 lifting strength KN																												
	起升速度 lifting speed v m/min		350		300		250		200		150		100		50														
	P	M	N.m	kW	N.m	kW	N.m	kW	N.m	kW	N.m	kW	N.m	kW	N.m	kW													
1500	1.500	0.500	464	49	253	27	398	42	217	23	35	181	19	266	28	145	16	199	21	109	12	133	14	73	7.6	67	6.9	36	3.8
1000	1.125	0.375	464	37	253	20	398	32	217	17	26	181	15	266	21	145	12	199	16	109	8.5	133	11	73	5.7	67	5.2	36	2.8
750	0.750	0.250	464	25	253	14	398	21	217	12	18	181	9.5	266	14	145	7.6	199	11	109	5.7	133	6.9	73	3.8	67	3.5	36	1.9
500	0.600	0.200	464	20	253	11	398	17	217	9.1	14	181	7.6	266	12	145	6.1	199	8.3	109	4.5	133	5.6	73	3.0	67	2.8	36	1.5
300	0.450	0.150	464	15	253	8.0	398	13	217	6.8	11	181	5.7	266	8.3	145	4.5	199	6.3	109	3.4	133	4.2	73	2.3	67	2.1	36	1.1
200	0.300	0.100	464	9.8	253	5.3	398	8.4	217	4.5	7.0	181	3.8	266	5.6	145	3.0	199	4.2	109	2.3	133	2.8	73	1.5	67	1.4	36	0.8
100	0.150	0.050	464	4.9	253	2.7	398	4.2	217	2.3	3.5	181	1.9	266	2.8	145	1.5	199	2.1	109	1.1	133	1.4	73	0.8	67	0.7	36	0.4
50	0.075	0.025	464	2.5	253	1.3	398	2.1	217	1.1	1.8	181	0.9	266	1.4	145	0.8	199	1.0	109	0.6	133	0.7	73	0.4	67	0.3	36	0.3

表11 table11(SWL50)

SWL SERIES WORM GEAR SCREW JACK

表11 table11(SWL50)

蜗杆转速 worm rotat- ional speed n	起升力 lifting strength KN																												
	500			450			400			350			300			200			100										
	P	M	N.m	P	M	N.m	P	M	N.m	P	M	N.m	P	M	N.m	P	M	N.m	P	M	N.m								
1500	1.6	0.625	848	448	47	764	80	401	42	679	71.1	353	37	594	62.2	316	33.1	509	53.3	271	28.4	339	35.5	180	18.9	169	17.7	90	9.4
1000	1.2	0.469	848	448	35.5	764	60	401	31	679	53.3	353	28.4	594	46.5	316	24.8	509	39.9	271	21.3	339	26.7	180	14.2	169	13.4	90	7.1
750	0.8	0.313	848	448	23.7	764	40	401	21	679	35.5	353	18.9	594	31	316	16.6	509	26.2	271	14.2	339	17.7	180	9.5	169	8.9	90	4.7
500	0.64	0.25	848	448	18.9	764	32	401	17	679	28.4	353	15.2	594	24.8	316	13.3	509	21.3	271	11.4	339	14.2	180	7.6	169	7.1	90	3.8
300	0.48	0.188	848	448	14.2	764	24	401	12.8	679	21.3	353	11.4	594	18.6	316	9.9	509	16	271	8.5	339	10.7	180	5.7	169	5.3	90	2.9
200	0.32	0.125	848	448	9.5	764	16	401	8.5	679	14.2	353	7.5	594	12.4	316	6.6	509	10.6	271	5.7	339	7.1	180	3.7	169	3.5	90	1.8
100	0.16	0.06	848	448	4.5	764	8	401	4	679	7.1	353	3.6	594	6.2	316	3.2	509	5.3	271	2.8	339	3.5	180	1.8	169	1.7	90	0.9
50	0.08	0.03	848	448	2.2	764	4	401	2	679	3.5	353	1.8	594	3.1	316	1.6	509	2.6	271	1.3	339	1.7	180	0.9	169	0.8	90	0.45

表12 table12(SWL100)

蜗杆转速 worm rotat- ional speed n	起升力 lifting strength KN																													
	1000			900			800			700			600			400			200											
	P	M	N.m	P	M	N.m	P	M	N.m	P	M	N.m	P	M	N.m	P	M	N.m	P	M	N.m									
1500	1.586	0.639	1938	203	1012	106	1747	183	915	96	1554	162	813	85	1359	142	711	74	1165	122	611	64	776	81	406	42.6	388	40.6	203	21.3
1000	1.189	0.479	1938	152	1012	80	1747	137	915	72	1554	122	813	64	1359	106	711	55	1165	91	611	48	776	61	406	32	388	30.5	203	16
750	0.793	0.319	1938	102	1012	53	1747	91	915	48	1554	81	813	42	1359	71	711	37	1165	61	611	32	776	41	406	21	388	21	203	10.5
500	0.635	0.255	1938	81.4	1012	42.5	1747	73	915	38	1554	65	813	34	1359	56	711	29	1165	48	611	25.5	776	32	406	17	388	16	203	8.5
300	0.476	0.192	1938	61	1012	32	1747	55	915	28.8	1554	49	813	25	1359	42	711	22	1165	36	611	19.2	776	24	406	12.7	388	12	203	6.3
200	0.317	0.128	1938	40.6	1012	21	1747	36	915	19.2	1554	32.5	813	17	1359	28	711	15	1165	24	611	12.8	776	16	406	8.5	388	8	203	4.2
100	0.159	0.064	1938	20.3	1012	10.6	1747	18.3	915	9.6	1554	16	813	8.5	1359	14	711	7.5	1165	12	611	6.4	776	8	406	4.3	388	4	203	2.1
50	0.080	0.032	1938	102	1012	5.3	1747	9.1	915	4.8	1554	8	813	4.2	1359	7	711	3.8	1165	6	611	3.2	776	4	406	2.1	388	2	203	1.05

SWL SERIES WORM GEAR SCREW JACK

表13 table13(SWL120)

蜗杆转速 worm rotat- ional speed n r/min	起升力 lifting strength KN																													
	起升速度 lifting speed v m/min		1200			1000			900			800			600			400			200									
	P	M	N.m	kW	N.m	kW	N.m	kW	N.m	kW	N.m	kW	N.m	kW	N.m	kW	N.m	kW	N.m	kW	N.m	kW	N.m	kW						
1500	2.083	0.694	3315	347	1656	173	2762	289	1380	144	2486	260	1242	130	2206	231	1104	115	1657	173	828	86.5	1103	115	552	57.5	551	57.5	276	28.5
1000	1.563	0.521	3315	260	1656	130	2762	217	1380	108	2486	195	1242	97	2206	173	1104	86	1657	130	828	65	1103	86	552	43	551	43	276	21.5
750	1.042	0.347	3315	173	1656	87	2762	144	1380	72	2486	130	1242	65	2206	115	1104	57	1657	86	828	43.5	1103	57	552	28.5	551	28.5	276	14.2
500	0.833	0.277	3315	138	1656	69	2762	115	1380	57	2486	104	1242	51	2206	92	1104	46	1657	69	828	34.5	1103	46	552	23	551	23	276	11.5
300	0.625	0.208	3315	104	1656	52	2762	86	1380	43	2486	78	1242	39	2206	69	1104	35	1657	52	828	26	1103	34.5	552	17.5	551	17.5	276	8.7
200	0.417	0.139	3315	69	1656	34	2762	58	1380	28	2486	52	1242	26	2206	46	1104	23	1657	34.5	828	17	1103	23	552	11.5	551	11.5	276	5.7
100	0.208	0.069	3315	34	1656	17	2762	29	1380	14	2486	26	1242	13	2206	23	1104	11.5	1657	17	828	8.5	1103	11.5	552	5.7	551	5.7	276	2.8
50	0.104	0.035	3315	17	1656	8.5	2762	14.5	1380	7	2486	13	1242	6.5	2206	11.5	1104	5.7	1657	8.5	828	4.2	1103	5.7	552	2.8	551	2.8	276	1.4

SWL SERIES WORM GEAR SCREW JACK

7 蜗杆副采用稀油润滑时的总效率 η (仅用于2型) 见表14

The general efficiency under the worm pair lubricated with thin oil (for 2nd type only) refer to table 14

表14 talbe 14

蜗杆 转速 worm rotat- ional speed r/min	型号SWL type SWL											
	2.5	2.5m	5	5M	10/15	10M/15M	20	20M	25	25M	35	35M
1500	0.283	0.214	0.257	0.188	0.29	0.236	0.273	0.275	0.262	0.21	0.248	0.204
1000	0.279	0.206	0.252	0.18	0.285	0.227	0.268	0.217	0.257	0.2	0.243	0.195
750	0.276	0.201	0.249	0.175	0.282	0.222	0.266	0.212	0.253	0.194	0.24	0.189
500	0.272	0.194	0.245	0.168	0.277	0.215	0.262	0.205	0.249	0.187	0.236	0.183
300	0.267	0.187	0.241	0.161	0.272	0.207	0.257	0.198	0.243	0.179	0.231	0.175
100	0.257	0.172	0.231	0.146	0.261	0.191	0.247	0.183	0.233	0.164	0.222	0.16
50	0.251	0.164	0.225	0.138	0.255	0.183	0.242	0.175	0.226	0.155	0.216	0.152

8 蜗杆轴伸的许用径向力 The safety radial strength of worm axial elongation

8.1 螺杆轴伸上, 由于安装齿轮、链轮或带轮所产生的径向力Fr, 其最大许用力与起升力和型号有关。在1/2处所许用的最大径向力和扭矩见图3和表15。

At the worm axial elongation, the radial strength Fr caused by installing gear, chain wheel or belt wheel, the Max safety strength has relation to lifting strength and jack type. The Max safety radial strength and torque at the half point, please see chart 3 and table 15.



图3
chart 3

表15 talbe 15

型号 type	Frmax N	Mtmax N.m
SWL2.5/2.5M	350	18
SWL5/5M	750	44.2
SWL10/10M/15/15M	1000	108
SWL20/20M	1300	182
SWL25/25M	2000	314
SWL35/35M	2300	398

注: 表中参数是按 $\phi = 30^\circ$ 或 330° 的计算。Note: parameters in the table counted as $\phi = 30^\circ$ or 330° .

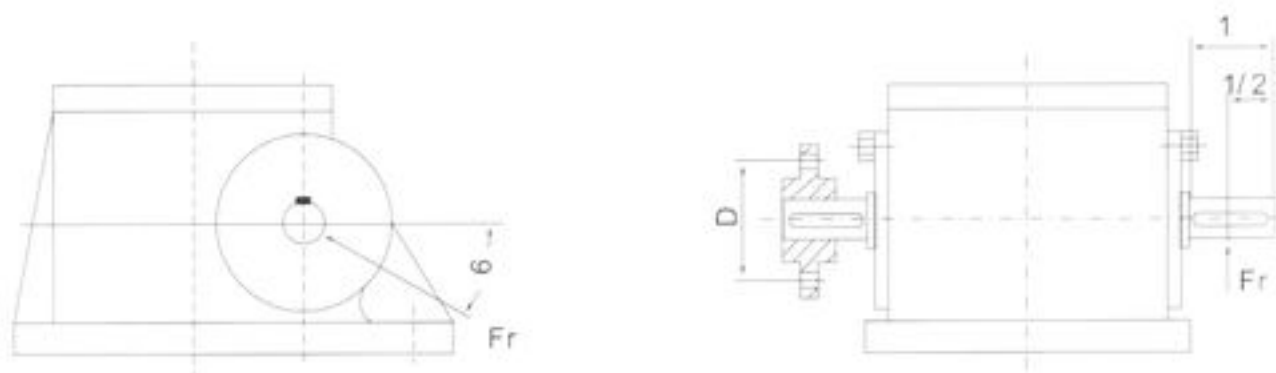
8.2 齿轮或带轮的最小直径:

$$D_{min} = 19100 \times \frac{P}{F_{max.n}} = \frac{2Mt}{F_{max}}$$

The Min diameter of gear or belt wheel

式中: Dmin——齿轮或带轮的最小直径, m

In Formula: the Min diameter of gear or belt wheel, m

P——驱动功率, kW
Drive power, kW

Frmax——最大径向力, N
Max radial strength, N

n——蜗杆转速, r/min
Worm rotational speed, r/min

Mt——驱动扭矩, N.m
Drive torques, N.m

$$D_{min} = 19100 \times \frac{P}{F_{max.n}} = \frac{2Mt}{F_{max}}$$

SWL SERIES WORM GEAR SCREW JACK

螺杆许用侧向力Fs和轴向力Fa与行程的关系见图4-10

Relation between the safety lateral strength, axial strength and stroke, refer to chart 4-10



图4 chart4



图5 chart5 SWL2.5

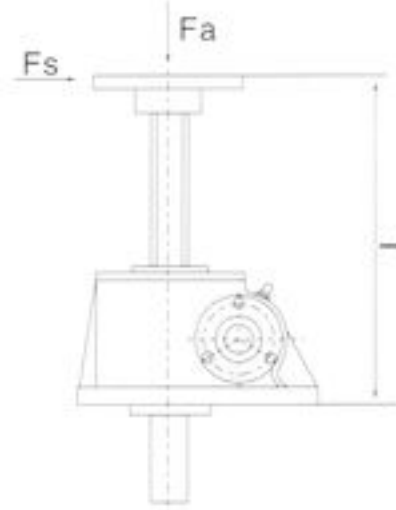

图6 chart5 SWL5

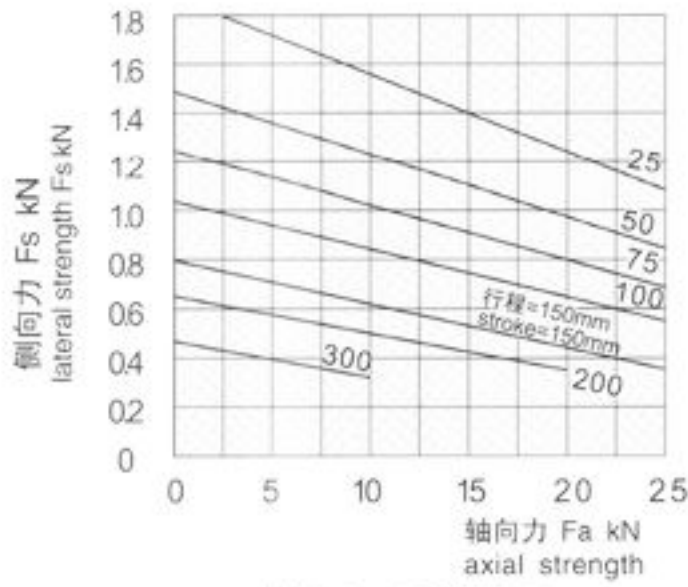

图7 chart7 SWL10/15

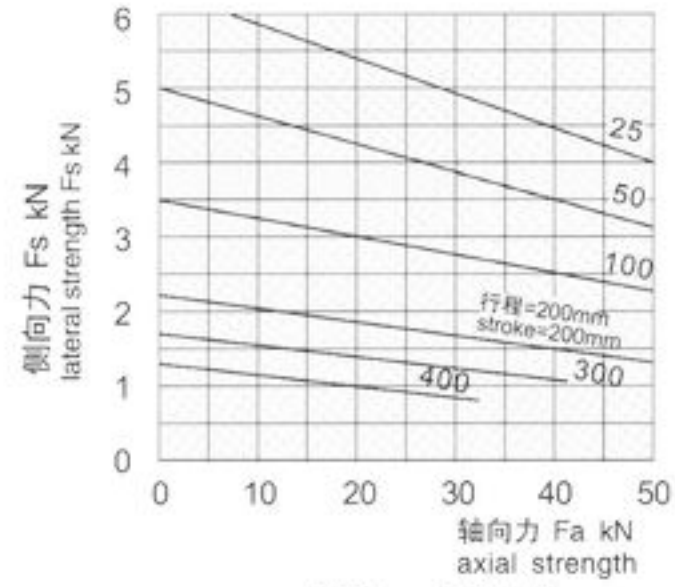

图8 chart8 SWL20

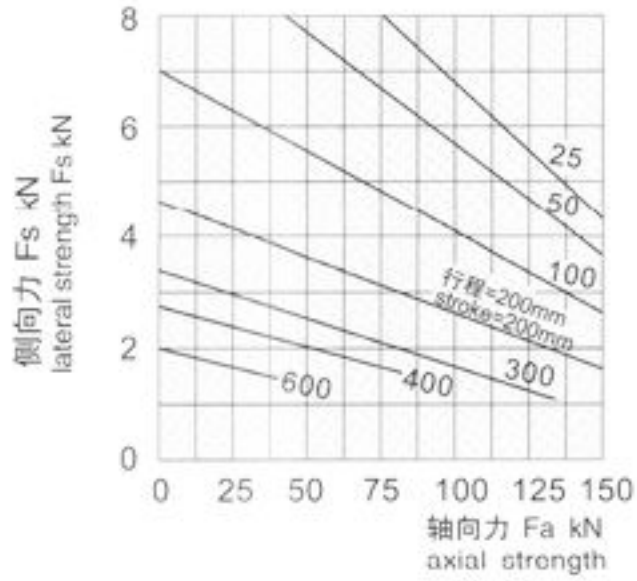

图9 chart9 SWL25

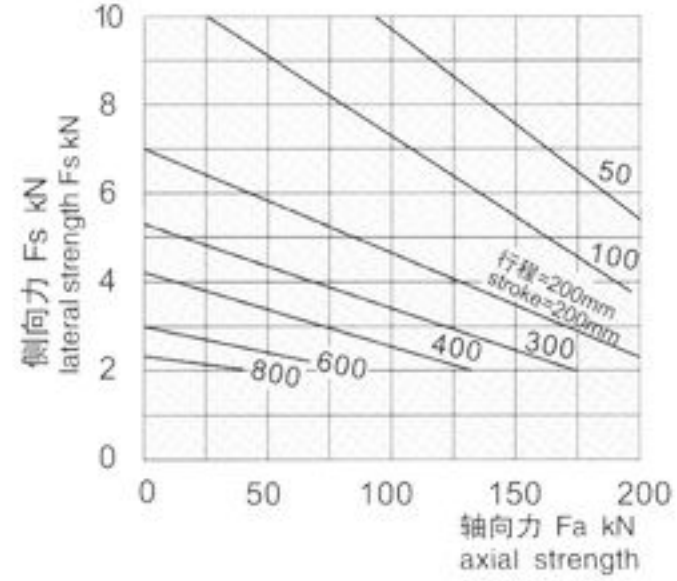

图10 chart10 SWL35

螺杆长度与极限负荷的关系 The relation between screw length and limit load

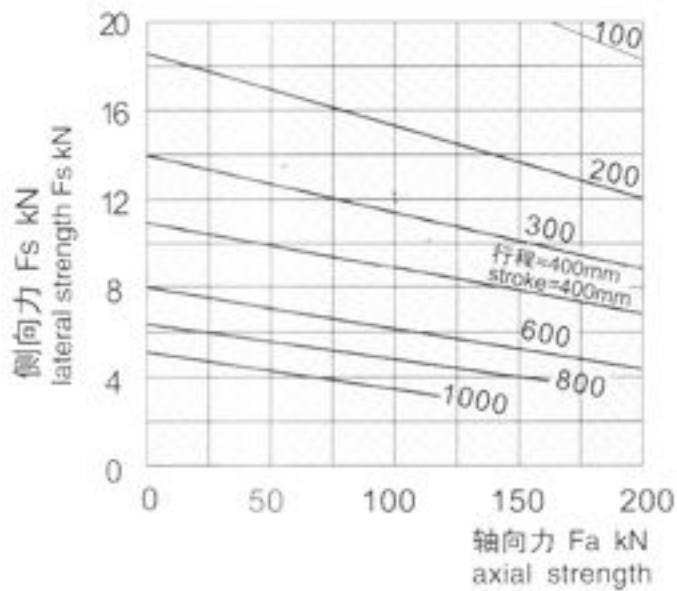
在欧拉负荷I和II情况下，螺杆长度与极限负荷的关系见图11-图17。
Under euro load 1 and 2, the relation between screw length and limit load, see chart 11-17

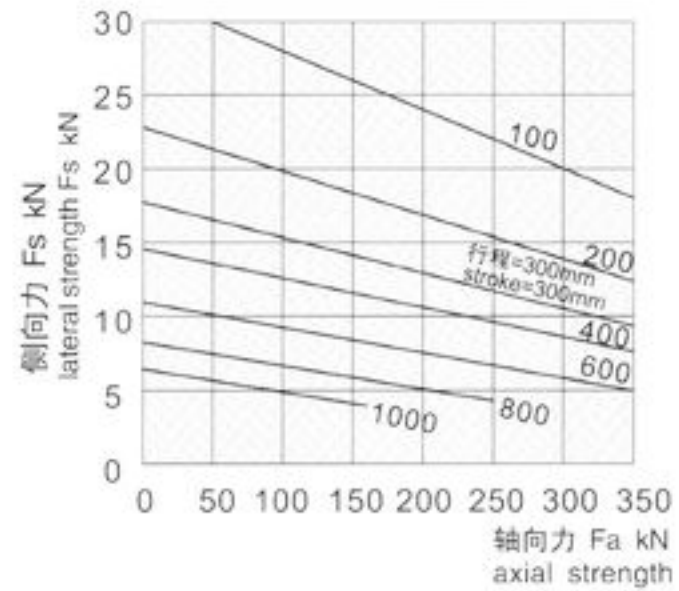

图11
Chart11



图12
chart12

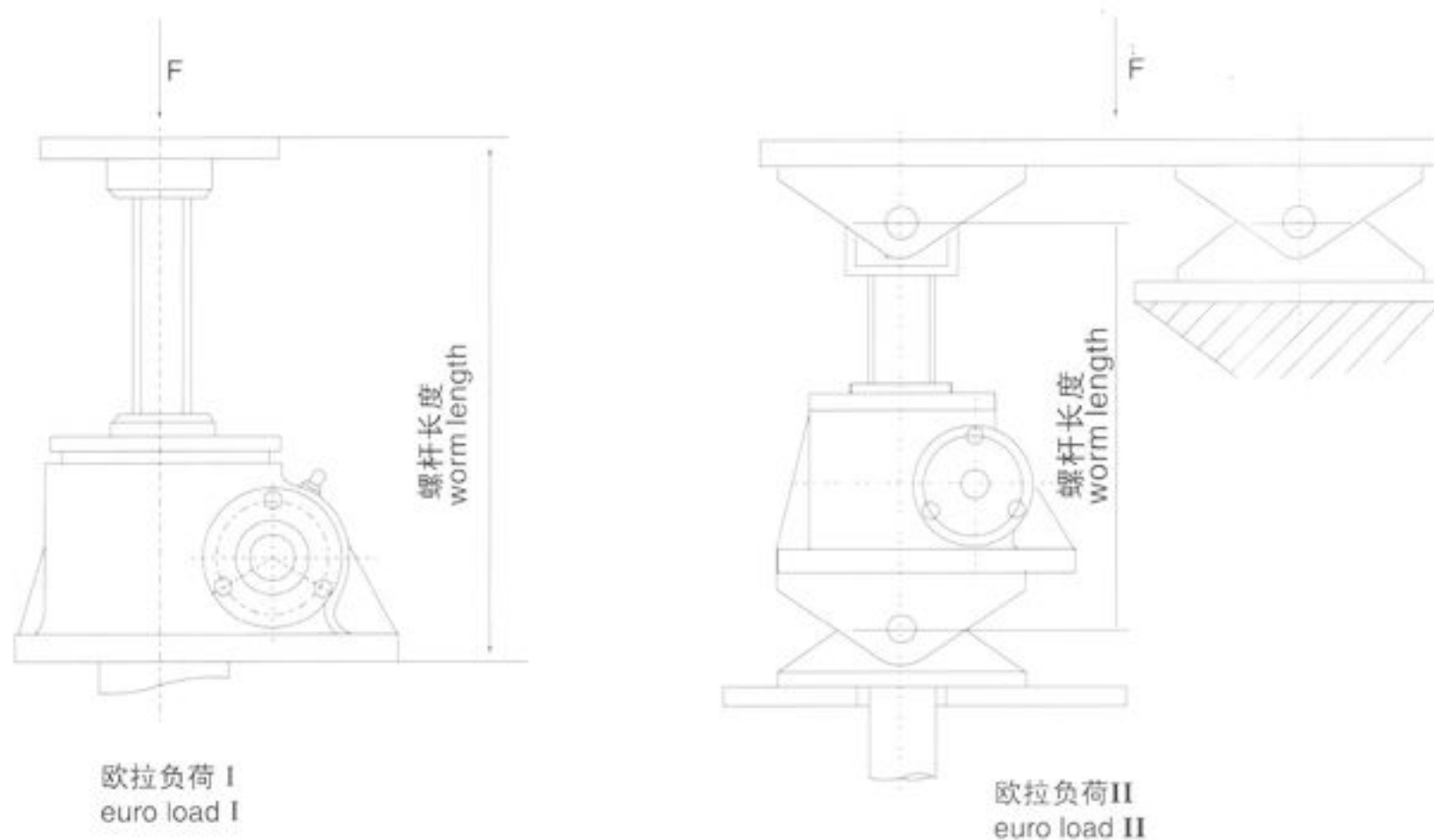

图13
Chart13

SWL SERIES WORM GEAR SCREW JACK

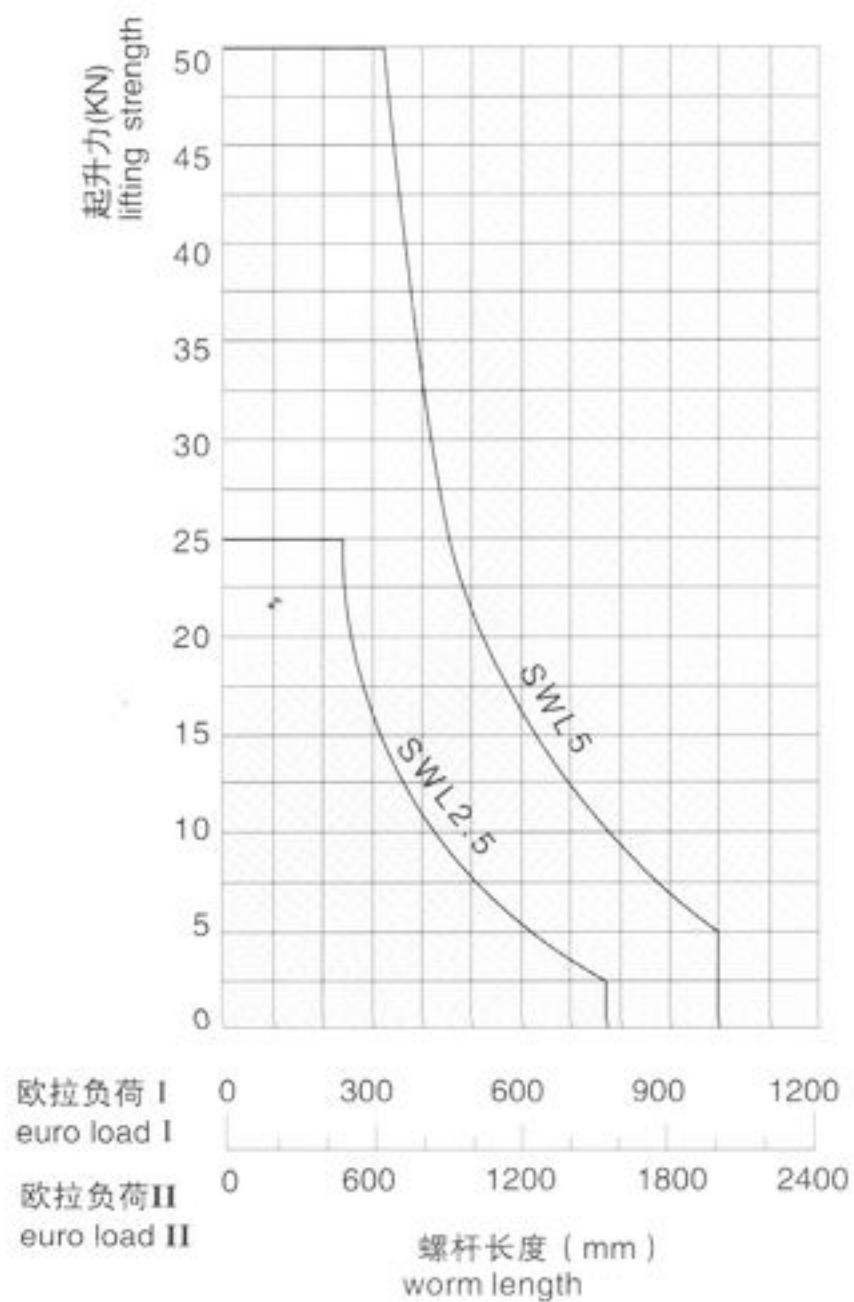

图14
chart14

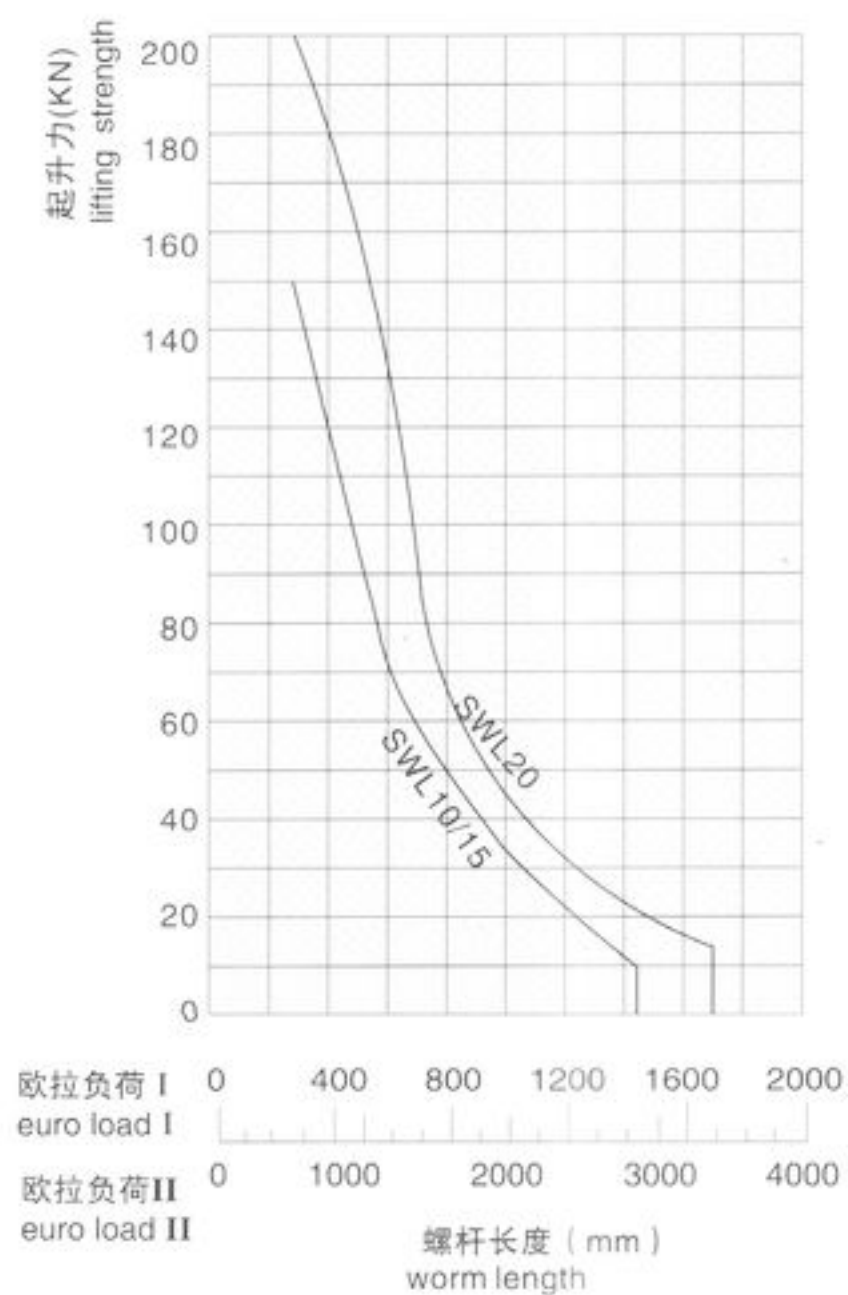

图15
chart15

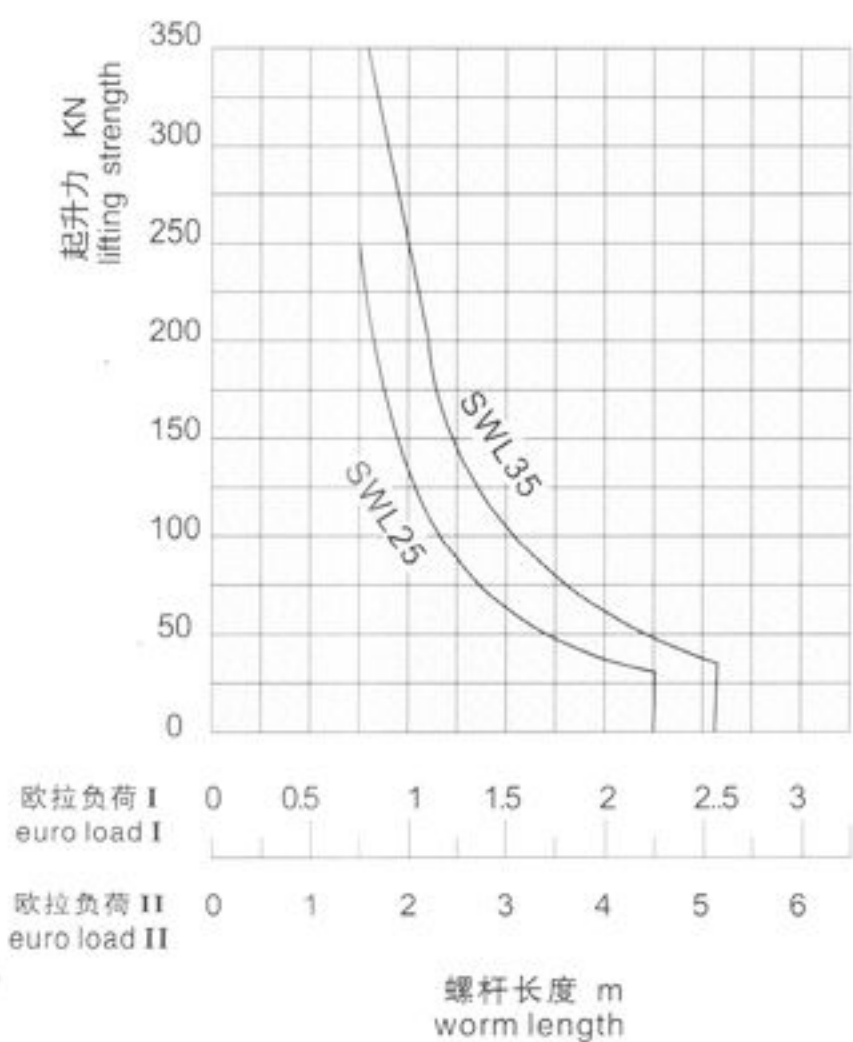

图16
chart16

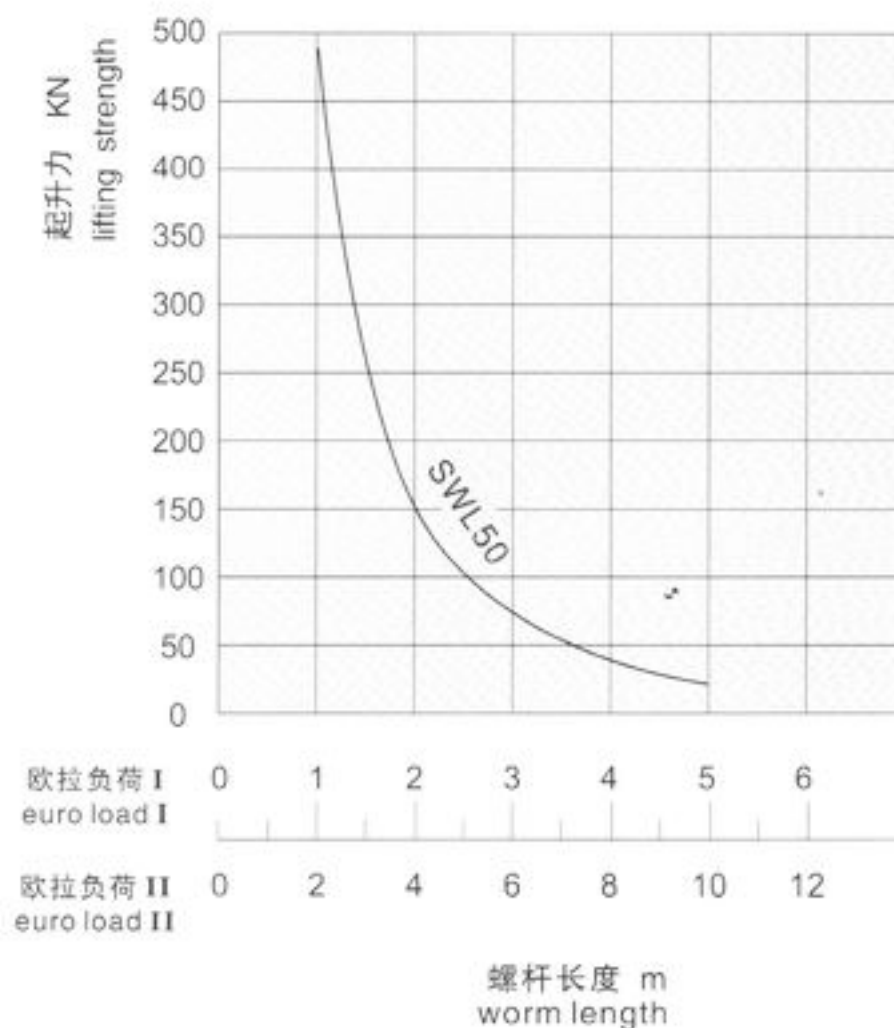

图17
chart17

SWL SERIES WORM GEAR SCREW JACK

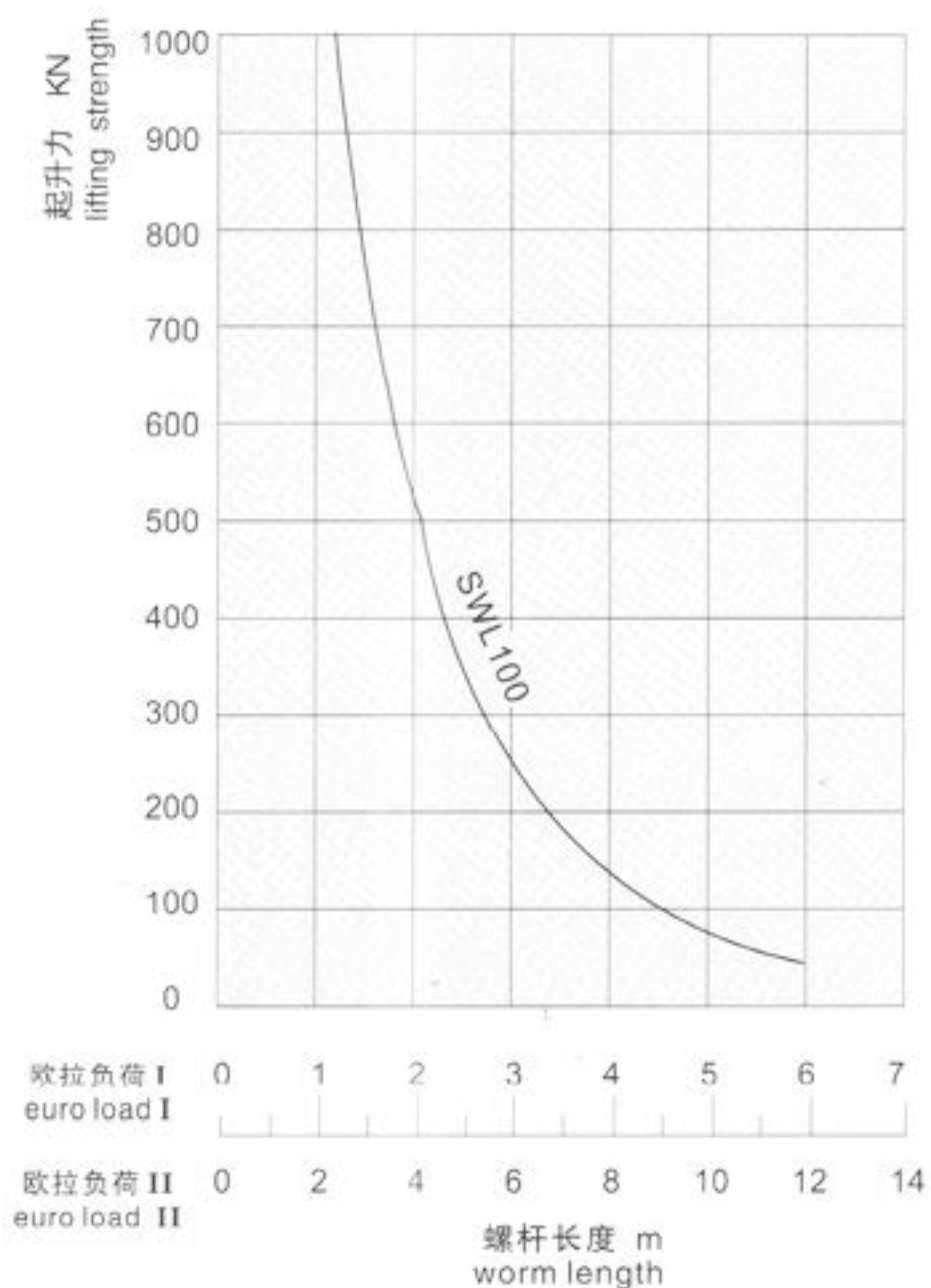
升降机的额定输入功率*见表16 The rated input power of jacks* see table 16

表16 table 16

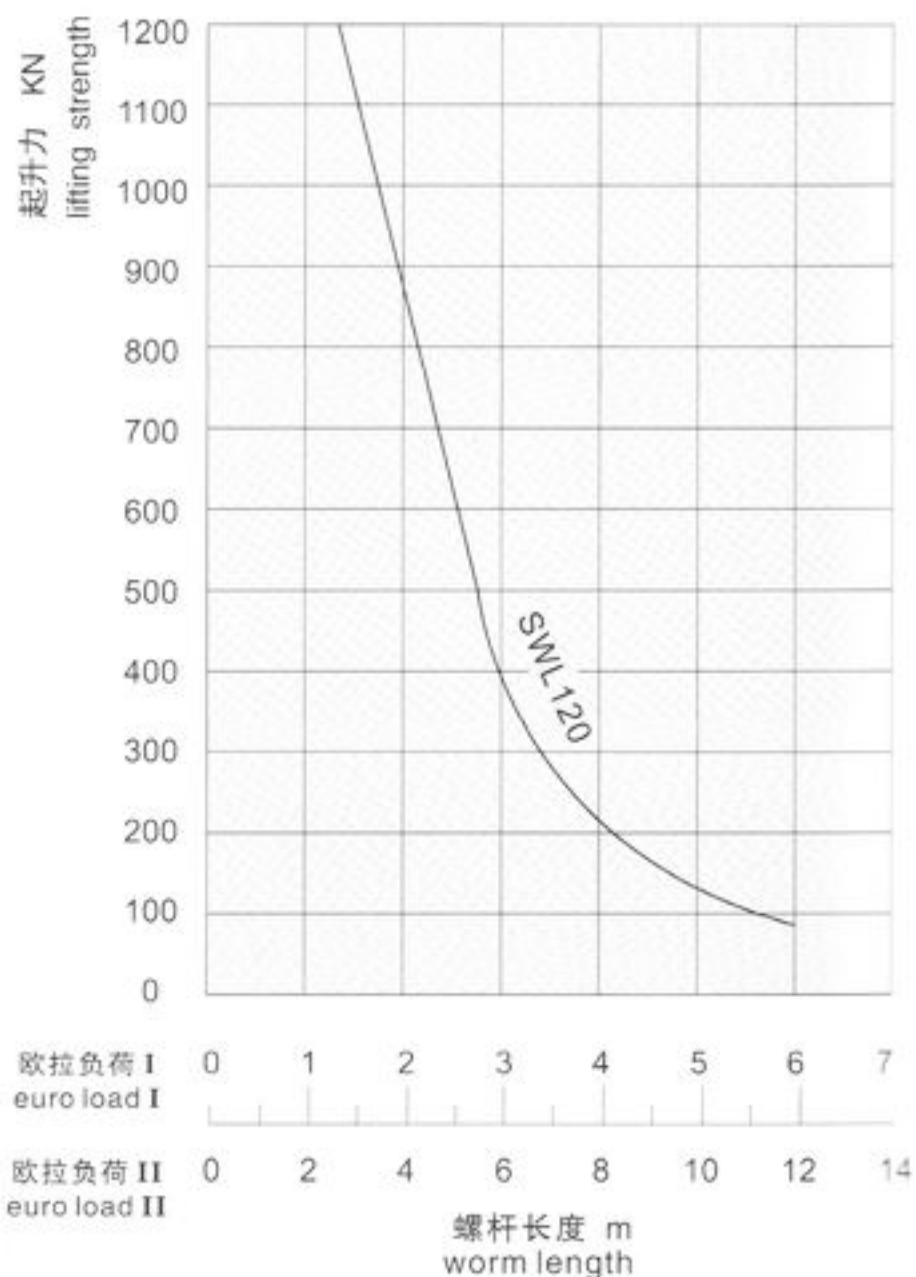
型号 type	输入转速r/min input rotational speed	普通速比 normal speed ratio	慢速比 slow speed ratio
SWL2.5	1500	1.45	1.45
	1000	1.01	0.32
	750	0.98	0.24
	500	0.82	0.19
SWL5	1500	2.59	0.84
	1000	1.92	0.7
	750	1.77	0.58
	500	1.45	0.43
SWL10/15	1500	3.47	1.31
	1000	2.68	1.06
	750	2.15	0.93
	500	1.89	0.64
SWL20	1500	4.02	1.65
	1000	2.94	1.39
	750	2.46	1.15
	500	2.31	0.77
SWL25	1500	6.38	2.26
	1000	4.42	1.87
	750	3.4	1.51
	500	2.67	1.22
SWL35	1500	13.06	6.36
	1000	11.89	5.28
	750	9.9	4.2
	500	6.56	3.13
SWL50	1000	11.74	6.29
	750	10.62	4.78
	500	8.25	3.63
	300	5.92	2.65
SWL100	1000	23.5	11.78
	750	21.1	9.44
	500	15.7	6.88
	300	10.9	4.94
SWL120	1000	56.41	28.2
	750	53.9	22.2
	500	39.8	16.44
	300	26.7	11.4

★表中功率值为载荷平稳无冲击、环境温度20°C、浸油润滑状态下的功率值。

★ The parameter power got in this condition: ambient temperature is 20°C, in the grease-lubricated case, the load beared without any impact